

HLC

High Level Circulators

Technical Guide

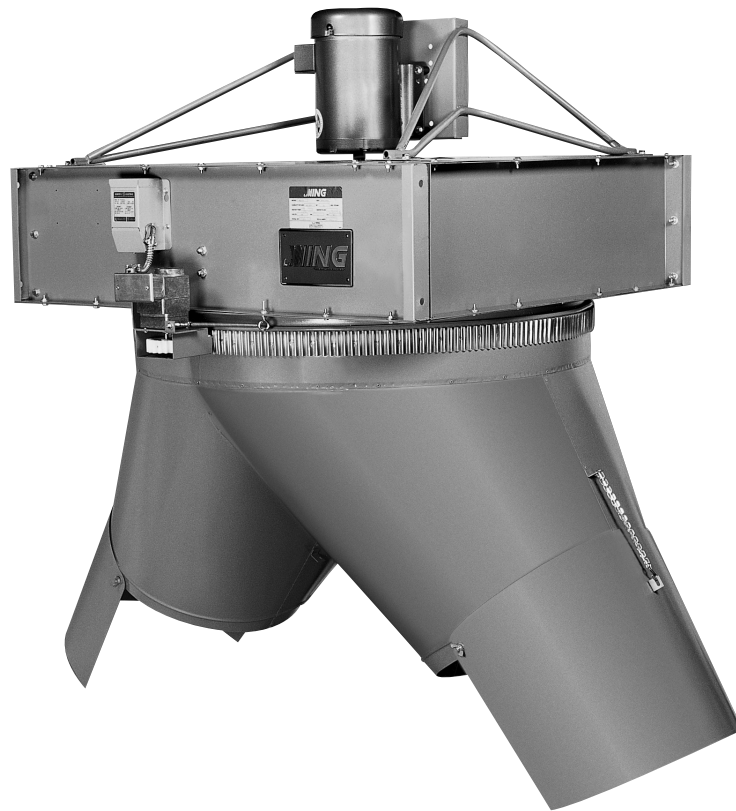

**A COST-EFFECTIVE SOLUTION FOR TEMPERATURE DESTRATIFICATION
IN OPEN SPACES**

Since 1875, the L.J. Wing Company has been a leader in providing innovative solutions for difficult HVAC problems. Wing HLC High level Circulators can offer efficient circulation for high ceiling buildings. This technical guide will help you size, select and specify the proper HLC model to satisfy your project's air circulation requirements. If you have questions, please contact your local L.J. Wing representative; he will be glad to assist you.



4830 Transport Drive, Dallas, TX 75247 Tel. (214) 638-6010
www.ljwing.com

In the interest of product improvement, L.J. Wing reserves the right to make changes without notice.

TABLE OF CONTENTS

Operation.....4
Model Number Description.....4
Selection.....5
Performance..... 5-6
Dimensions..... 7-9
Electrical.....10-11
Typical Specification.....12
Typical Schedule12

PRODUCT DESCRIPTION

Product Offering

C000640, C000652

Recirculated Air Arrangement

When installed at the ceiling level as depicted below, Wing's HLC High level Circulators recirculate warm air rising from the floor to maintain an extremely low floor-to-ceiling temperature differential.

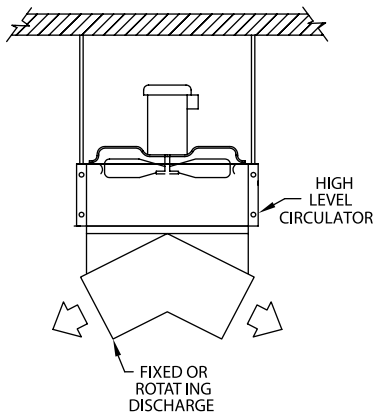

Recirculation plus Ventilation Air Arrangement

With the addition of optional three way mixing box, intake hood and roof curb as shown below, the HLC unit can modulate the discharge temperature of recirculated air with fresh outside air during the spring and fall. This helps prevent heating system override due to outside temperature fluctuations. The three-way mixing box is furnished with modulating motorized return and outside air dampers and an airstream thermostat to control temperature and reduce heating expense.

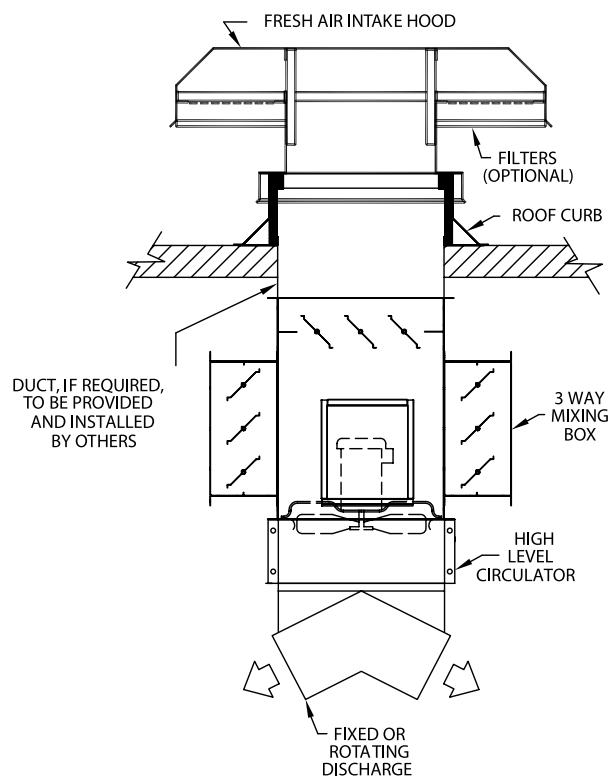

Model Number Description

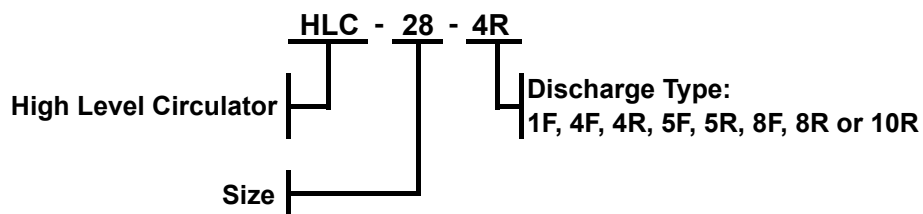

SELECTION AND PERFORMANCE

Selection Procedure

From the discharge performance table on page 6, select the smallest unit at the required mounting height that gives coverage equal to the area of the building.

Notes:

1. The mounting height is defined as the distance from the floor to the bottom of the discharge outlet.
2. Mounting height and coverage are maximum values based on 90 degrees F entering air temperature and 65 degrees F floor temperature. Consult your L.J. Wing representative for unit selection at other conditions

Example: Select HLC unit for a mounting height of 30 feet to cover an area of 190 feet by 190 feet.

Solution: Evaluating each of the discharge types:

Type 1F: No selection gives the required coverage

Type 4R: Size 36 is required

Type 4F: No selection gives the required coverage

Type 5F: Size 43 is required

Type 5R: Size 43 is required

Type 8F: No selection gives the required coverage

Type 8R: To get the coverage requires a size 43 unit at a mounting height of 89 feet, so this is not a good selection.

Type 10R: To get the coverage requires a size 40 unit at a mounting height of 86 feet, so this is not a good selection.

Proper choice is a size 36 HLC unit fitted with a type 4R discharge.

Performance

Motor Data

SIZE	CFM (AT INLET)	DIRECT DRIVE MOTOR				BELT DRIVE MOTOR			
		SINGLE PHASE		THREE PHASE		SINGLE PHASE		THREE PHASE	
		HP	RPM	HP	RPM	HP	RPM	HP	RPM
19	2,000	1/4	1140	1/4	1140	NOT AVAILABLE			
20	2,550	1/3	1725	1/3	1725				
22	2,750	1/4	1140	1/4	1140				
23	3,600	1/2	1140	1/2	1140				
25	4,300	1/2	1140	1/2	1140				
26	5,500	3/4	1140	3/4	1140				
28	6,500	NOT AVAILABLE		3/4	850	3/4	1725	3/4	1725
30	7,000			3/4	850	3/4	1725	3/4	1725
33	8,700			1-1/2	860	1-1/2	1725	1-1/2	1740
36	10,000			1-1/2	860	1-1/2	1725	1-1/2	1740
38	13,000			2	855	2	1725	2	1725
40	16,500			3	850	3	1725	3	1725
43	21,500			5	855	5	1725	5	1750
44	27,000			7-1/2	1160	7-1/2	1725	7-1/2	1760

NOTES:

1. Integral OSHA-approved fan guards are furnished as standard on all units up to and including size 26. For larger sizes, OSHA-approved fan guards are optional.
2. Contact your local L.J. Wing representative to obtain sound data when required.

DISCHARGES

Performance

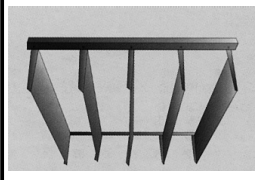
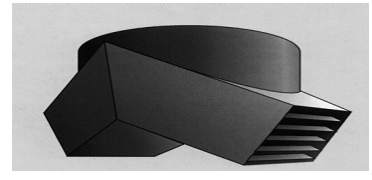
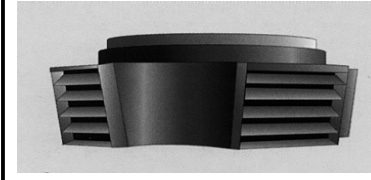
TYPE 1F			TYPES 4F & 4R			TYPES 5F & 5R		
								
SIZE	MH	CF	MH	CR	CF	MH	CR	CF
19	16	34x68	17	110x110	55x110	11	66x66	66x66
20	17	36x72	18	124x124	62x124	12	73x73	73x73
22	18	38x76	19	126x126	63x126	13	76x76	76x76
23	20	41x82	21	140x140	70x140	14	83x83	83x83
25	21	44x88	22	147x147	74x147	14	86x86	86x86
26	23	49x98	24	160x160	80x160	15	95x95	95x95
28	24	52x104	25	160x160	80x160	16	100x100	100x100
30	26	56x112	26	170x170	85x170	17	110x110	110x110
33	29	62x124	28	180x180	90x180	18	125x125	125x125
36	31	68x132	31	190x190	95x190	19	130x130	130x130
38	35	75x150	36	225x225	113x225	22	150x150	150x150
40	37	80x160	40	225x225	113x225	25	165x165	165x165
43	42	106x212	48	305x305	153x305	30	195x195	195x195
44	47	133x266	53	350x350	175x350	33	225x225	225x225

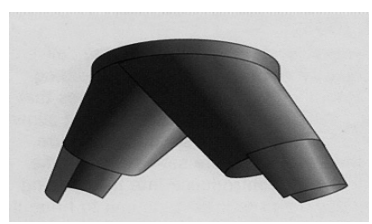
TYPE 10R			TYPES 8R & 8F		
					
SIZE	MH	CR	MH	CR	CF
19	---	---	29	60x60	30x60
20	---	---	32	66x66	33x66
22	---	---	34	72x72	36x72
23	---	---	37	80x80	40x80
25	---	---	39	85x85	43x85
26	---	---	43	92x92	46x92
28	54	117x117	44	95x95	48x95
30	58	126x126	48	105x105	53x105
33	65	145x145	54	120x120	60x120
36	68	152x152	58	125x125	63x125
38	79	175x175	68	145x145	73x145
40	86	190x190	74	160x160	80x160
43	105	230x230	89	195x195	98x195
44	117	255x255	98	215x215	108x215

Notes:

- MH = Mounting height in feet; CF = Coverage in feet for a fixed discharge; CR = Coverage in feet for a revolving discharge.
- Mounting height is the distance from the floor to the bottom of the discharge outlet.
- Mounting height and coverage are based on 90 deg. F EAT and 65 deg. F floor temperature. For operation at other conditions, consult your Wing representative for recommendations.

DIMENSIONS

Basic Unit

C000649

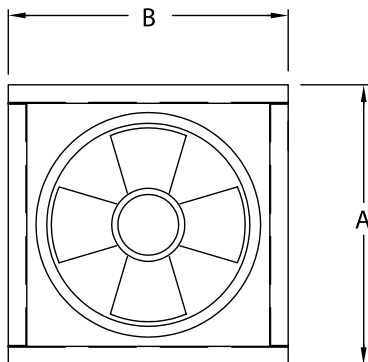

PLAN VIEW

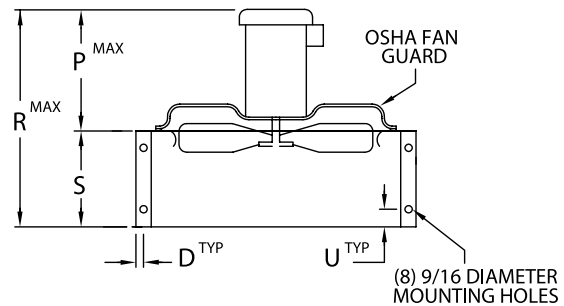

SIDE ELEVATION

NOTE : HLC-19 THRU HLC-26 PROVIDED WITH OSHA FAN GUARD AS SHOWN.
OSHA FAN GUARD OPTIONAL ON SIZES HLC-28 THRU HLC-44.

SIZE	DIMENSIONS (inches)									
	A	B	D	E	F	G	P	R	S	U
19	22 3/4	22 3/4	3/4	2 1/2	5 1/8	7 5/16	11	20	9	1
20	27 3/4	22 3/4	3/4	2 1/2	5 1/8	7 5/16	11	20	9	1
22	27 3/4	27 3/4	3/4	2 5/8	5	7 7/16	11 1/16	20 1/16	9	1
23	32 3/4	27 3/4	3/4	2 5/8	5	7 7/16	11 1/16	20 1/16	9	1
25	32 3/4	32 3/4	3/4	2 5/8	5	7 7/16	11 1/16	20 1/16	9	1
26	38 1/8	32 3/4	3/4	2 5/8	5	7 7/16	11 3/16	20 3/16	9	1
28	39 1/8	39 1/8	1	3 3/8	7	9 5/8	13 7/8	25 7/8	12	1 1/2
30	39 1/8	39 1/8	1	3 3/8	7	9 5/8	13 7/8	25 7/8	12	1 1/2
33	45 1/8	39 1/8	1	3 3/8	7	9 5/8	13 7/8	25 7/8	12	1 1/2
36	45 1/8	45 1/8	1	3 3/8	7	9 5/8	13 7/8	25 7/8	12	1 1/2
38	45 1/8	45 1/8	1	3 3/8	7	9 5/8	14 11/16	26 11/16	12	1 1/2
40	63 1/8	51 5/8	7/8	31 9/16	11 1/4	15 1/4	14 1/2	38 1/2	24	1
43	63 1/8	51 5/8	7/8	31 9/16	11 1/4	15 1/4	20	44	24	1
44	63 1/8	51 5/8	7/8	31 9/16	11 1/4	15 1/4	20	44	24	1

DIMENSIONS

Discharges

C000650

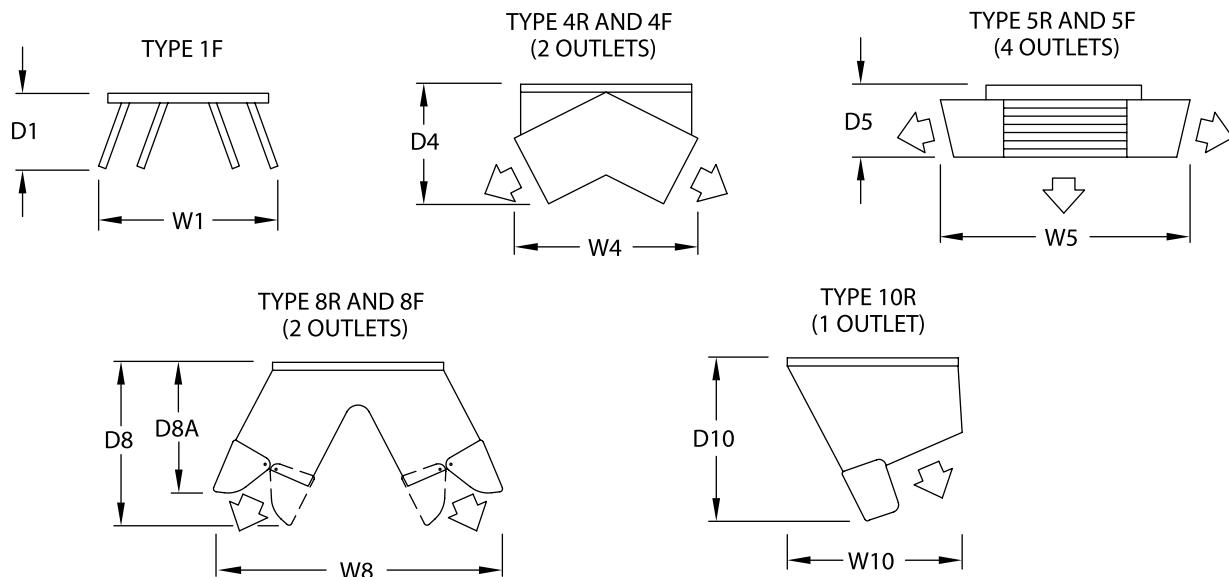

SIZE	DIMENSIONS (inches)										
	D1	W1	D4	W4	D5	W5	D8	D8A	W8	D10	W10
19	7 1/8	31 1/8	18 9/16	25	11 5/16	28 15/16	27 3/4	25	41	-----	-----
20	7 1/8	31 1/8	18 9/16	25	11 5/16	28 15/16	27 3/4	25	41	-----	-----
22	8 1/8	38 1/16	19 7/8	29 1/4	12	34 1/2	30	27	47 1/2	-----	-----
23	8 1/8	38 1/16	19 7/8	29 1/4	12	34 1/2	30	27	47 1/2	-----	-----
25	9 1/8	45	23 15/16	39	15	40	31 3/4	28 1/2	53 1/2	-----	-----
26	9 1/8	45	23 15/16	39	15	40	31 3/4	28 1/2	53 1/2	-----	-----
28	10 1/8	52 3/8	28 3/8	42	17 5/8	50	35 3/4	34	64	40 7/16	39 11/16
30	10 1/8	52 3/8	28 3/8	42	17 5/8	50	35 3/4	34	64	40 7/16	39 11/16
33	10 1/8	52 3/8	28 3/8	42	17 5/8	50	35 3/4	34	64	40 7/16	39 11/16
36	10 1/8	58 3/8	32 15/16	47 1/4	19 1/4	57	46 1/4	42 1/2	77	46 1/8	44 9/16
38	10 1/8	58 3/8	32 15/16	47 1/4	19 1/4	57	46 1/4	42 1/2	77	46 1/8	44 9/16
40	10 1/8	64 7/8	37 1/16	54	21 1/8	66 1/2	53 3/4	48 1/2	89 1/2	53 5/8	53 3/16
43	10 1/8	64 7/8	37 1/16	54	21 1/8	66 1/2	53 3/4	48 1/2	89 1/2	53 5/8	53 3/16
44	10 1/8	64 7/8	39	54	23	66 1/2	52 3/4	46 3/4	86	51 3/8	56

Notes: (1) Values shown for D4, D5, D8, and D8A apply to revolving discharge only. To get dimension of fixed discharge, subtract 13/16" from values shown for sizes 19 through 33 and for larger sizes, subtract 1 3/4".

SIZE	Total Unit Weight with Discharge of Stated Size (lbs.)							
	1F	4F	4R	5F	5R	8F	8R	10R
19	74	104	110	100	107	102	109	-----
20	87	116	123	111	118	113	120	-----
22	91	133	140	124	131	129	136	-----
23	109	146	153	143	150	144	151	-----
25	120	166	204	165	203	161	199	-----
26	148	190	229	191	229	191	229	-----
28	205	278	323	281	325	273	317	310
30	205	278	323	281	325	273	317	310
33	239	305	349	309	354	303	347	341
36	251	366	470	348	452	356	460	434
38	282	397	501	379	483	387	491	465
40	513	656	776	686	806	651	770	741
43	647	790	910	820	940	785	904	875
44	682	832	951	863	983	815	934	911

DIMENSIONS

Accessories

C000621

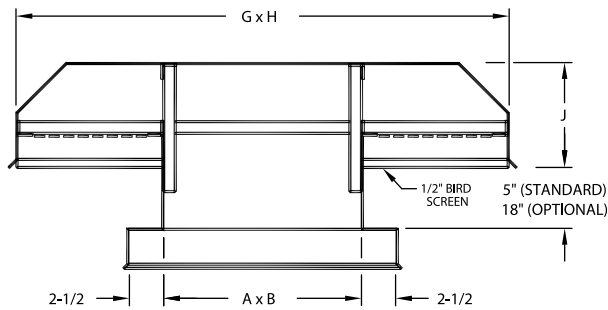

INTAKE HOOD

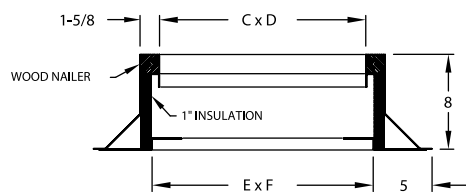

FLAT ROOF CURB SECTION

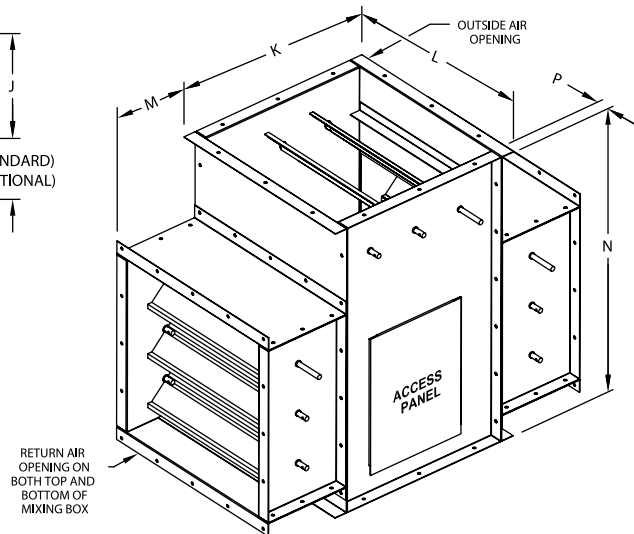

MIXING BOX

HLC	DIMENSIONS														WEIGHTS		
	A	B	C	D	E	F	G	H	J	K	L	M	N	P	IH	RC	MB
19	17 3/4	17 3/4	18 1/2	18 1/2	19 3/4	19 3/4	31 1/4	32	7 1/4	22 3/4	22 3/4	8 1/2	32	1 1/2	273	25	138
20	22 3/4	17 3/4	23 1/2	18 1/2	24 3/4	19 3/4	31 1/4	41	7 1/4	27 3/4	27 3/4	8 1/2	32	1 1/2	303	27	172
22	27 3/4	22 3/4	23 1/2	23 1/2	24 3/4	24 3/4	40 1/16	41	8 1/4	27 3/4	27 3/4	8 1/2	32	1 1/2	333	29	183
23	27 3/4	22 3/4	28 1/2	23 1/2	29 3/4	24 3/4	40 1/16	49	9 1/4	32 3/4	27 3/4	8 1/2	32	1 1/2	363	32	180
25	27 3/4	27 3/4	28 1/2	28 1/2	29 3/4	29 3/4	48 7/8	49	10 1/4	32 3/4	32 3/4	8 1/2	32	1 1/2	393	34	198
26	34 1/8	27 3/4	34 7/8	28 1/2	36 1/8	29 3/4	48 7/8	59	10 1/4	38 1/8	32 1/8	8 1/2	32	1 1/2	431	37	210
28	33 1/8	33 1/8	33 7/8	33 7/8	35 1/8	35 1/8	58	59	11 1/4	39 1/8	39 1/8	8	39	2	470	39	265
30	33 1/8	33 1/8	33 7/8	33 7/8	35 1/8	35 1/8	58	59	11 1/4	39 1/8	39 1/8	8	39	2	470	39	265
33	39 1/8	33 1/8	39 7/8	33 7/8	41 1/8	35 1/8	58	70	12 1/4	45 1/8	39 1/8	8	39	2	506	42	274
36	39 1/8	39 1/8	39 7/8	39 7/8	41 1/8	41 1/8	68 15/16	69	13 1/4	45 1/8	45 1/8	8	39	2	542	45	288
38	39 1/8	39 1/8	39 7/8	39 7/8	41 1/8	41 1/8	68 15/16	69	13 1/4	45 1/8	45 1/8	8	39	2	542	45	288
40	57 1/8	45 5/8	57 7/8	46 3/8	59 1/8	47 5/8	80 3/8	101	16 1/4	63 1/8	51 1/8	8	39	2	689	58	375
43	57 1/8	45 5/8	57 7/8	46 3/8	59 1/8	47 5/8	80 3/8	101	16 1/4	63 1/8	51 1/8	8	39	2	689	58	375
44	57 1/8	45 5/8	57 7/8	46 3/8	59 1/8	47 5/8	80 3/8	101	16 1/4	63 1/8	51 1/8	8	39	2	689	58	375

Notes:

1. All dimensions in inches.
2. All weights in pounds.
3. Weight nomenclature: IH = Intake Hood; RC = Roof Curb; MB = Mixing Box.

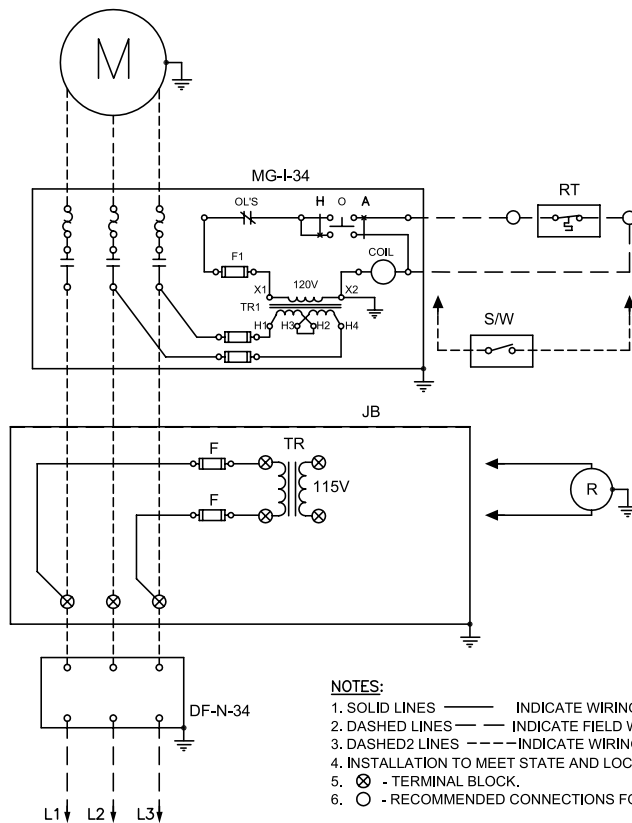

OPTIONS:

- (MG-I-34) MAGNETIC STARTER - IEC1
- (MG-N-34) MAGNETIC STARTER - NEMA1
- (DF-N-34) FUSED DISCONNECT SWITCH - NEMA1
- (R) REVOLVING DISCHARGE MOTOR
- (S/W) SUMMER/WINTER SWITCH
- (F) FUSE
- (RT) ROOM THERMOSTAT - LINE VOLTAGE
- (DS) DOOR SWITCH
- (TR) TRANSFORMER
- (JB) JUNCTION BOX

NOTES:

1. SOLID LINES ——— INDICATE WIRING BY WING.
2. DASHED LINES - - - - INDICATE FIELD WIRING BY OTHERS.
3. DASHED2 LINES - - - - - INDICATE WIRING BY WING OR BY OTHERS (SEE OPTIONS LISTING ABOVE).
4. INSTALLATION TO MEET STATE AND LOCAL BUILDING CODES.
5. ⊗ - TERMINAL BLOCK.
6. ○ - RECOMMENDED CONNECTIONS FOR CONTROL COMPONENTS.

Wiring

All units should be equipped with either a manual or a magnetic starter. (Both of these items are available as options). They may be factory mounted and wired or shipped loose. For your convenience, both NEMA-rated and IEC-rated starters are offered.

Smaller single-phase motors may be controlled with a line voltage thermostat, while larger single phase and all three phase motors require a magnetic starter, with the thermostat controlling the holding coil.

Models equipped with revolving discharges are supplied with the “R” drive motor pre-wired. Units supplied for any electrical service other than 115 volts/single-phase or 230 volts/three-phase are factory equipped with a step-down transformer.

Fan motors, “R” Drive (revolving discharge) motors, and room thermostats are available in explosion-proof versions. The required Division, Class, and Group must be known to properly select explosion-proof items.

ELECTRICAL

Amp Draw Table

ITEM	SOURCE	ELECTRICAL SERVICE	MOTOR AMPS AT GIVEN MOTOR HORSEPOWER							
			1/2	3/4	1	1 1/2	2	3	5	7 1/2
A	Fan Motor	208V 3 Ph	2.4	3.5	4.6	6.6	7.5	10.6	16.7	24.2
		230V 3 Ph	2.2	3.2	4.2	6.0	6.8	9.6	15.2	22.0
		460V 3 Ph	1.1	1.6	2.1	3.0	3.4	4.8	7.6	11.0
		575V 3 Ph	0.9	1.3	1.7	2.4	2.7	3.9	6.1	9.0
B	Control Transformer	ELECTRICAL SERVICE	CONTROL CIRCUIT AMPS							
		208V 3 Ph	0.5							
		230V 3 Ph	0.4							
		460V 3 Ph	0.2							
		575V 3 Ph	0.2							

Notes:

1. Above motor amps are based on the latest edition of the National Electrical Code.
2. Control circuit amps are based on standard controls.
3. Steps to size optional disconnect switch:
 - A. Using the required fan motor HP from page 5 and the given electrical service, look up the fan motor amp draw from Item A in the above chart.
 - B. Look up the control circuit amps from Item B in above chart.
 - C. Add Fan Motor amps from Step A to Control Circuit amps of Step B, then multiply result by 1.25 to get required size of optional disconnect switch.

SPECIFICATIONS AND SCHEDULE

Typical Specification

Furnish High Level Circulators as manufactured by L.J. Wing, Dallas, Texas. The units shall be completely factory assembled with performance as shown on the schedule.

Equipment shall be designed for the elimination of stratification in open spaces and shall maintain a temperature gradient between the floor and ceiling of less than of one eighth of a degree Fahrenheit per foot.

Each unit shall be provided with a non-overloading fan wheel directly connected to a constant speed motor with prelubricated, sealed ball bearings. The fan wheel shall be dynamically balanced and used in conjunction with an inlet venturi.

Unit casing shall be constructed of fourteen gauge, galvanized steel. Unit casing and discharge shall be finished with air-dried alkyd resin enamel.

Each High Level Circulator shall be provided with a (fixed discharge)(revolving discharge consisting of a gear-driven revolving outlet mounted on a sheet steel air chamber that is properly balanced and suspended from the unit casing on a dual, prelubricated, sealed ball bearing assembly). (Type 8F, 8R and 10R only: Each outlet opening shall be fitted with adjustable deflectors to permit adjusting the discharged air to provide proper coverage at the floor.)

Typical Schedule

Model no.	Airflow Rate (CFM)	Mounting Height (feet)	Coverage (feet x feet)	Motor Horsepower (HP)	Electrical Service (volt/ph./Hz)
HLC-28-4R	6,500	25	160 x 160	3/4	230/3/60